

SP

VT7QC 1 - 022 - 1 R 00 - B 1 - 00 *

Series

Mounting

- 1 - SAE B
- 2 - SAE C

Camring

(Delivery @ 0 bar & 1500 rpm)

| | |
|----------------------------|---------------------------|
| * 003/B03/Y03 = 16.2 l/min | 015/B15/Y15 = 75.1 l/min |
| 005/B05/Y05 = 25.8 l/min | 017/B17/Y17 = 87.4 l/min |
| 006/B06/Y06 = 31.9 l/min | 020/B20/Y20 = 95.7 l/min |
| 008/B08/Y08 = 39.6 l/min | 022/B22/Y22 = 105.4 l/min |
| 010/B10/Y10 = 51.1 l/min | 025/B25/Y25 = 118.9 l/min |
| 012/B12/Y12 = 55.6 l/min | 028/B28/Y28 = 133.2 l/min |
| 014/B14/Y14 = 69.0 l/min | 031/B31/Y31 = 150.0 l/min |

* '0' - Uni-directional 'B' - Bi-directional 'Y' - Bi-directional for cold start

Type of shaft

- 1 - Keyed (SAE B)
- 2 - Keyed (non SAE)
- 3 - Splined (SAE B)
- 4 - Splined (SAE BB)

Modifications

Mounting W/connection variables

| | UNC | | METRIC | |
|---|--------|------|--------|------|
| | 00 | 01 | M0 | M1 |
| P | 1" | 3/4" | 1" | 3/4" |
| S | 1 1/2" | | | |

Seal class

- 1 - S1 (for mineral oil)
- 4 - S4 (for fire resistant fluids)
- 5 - S5 (for mineral oil and fire resistant fluids)

Design letter

Porting combination

00 - standard

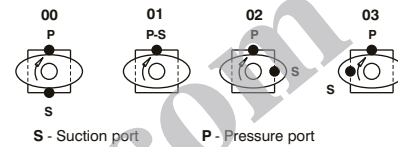

Direction of rotation (view on shaft end)

- R - clockwise
- L - counter-clockwise

INTERNAL LEAKAGE (TYPICAL)

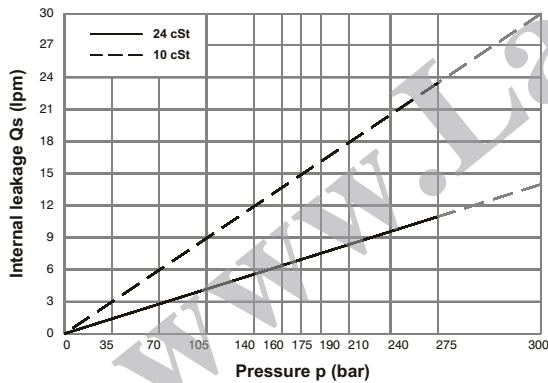

Do not operate pump more than 5 seconds at any speed or viscosity if internal leakage is more than 50% of theoretical flow.

NOISE LEVEL (TYPICAL)

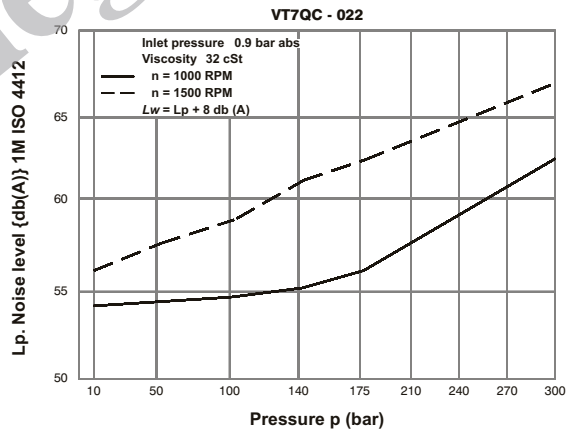

HYDROMECHANICAL POWER LOSS (TYPICAL)

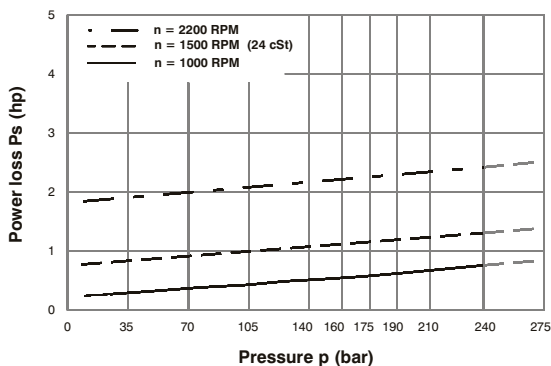

PERMISSIBLE RADIAL LOAD

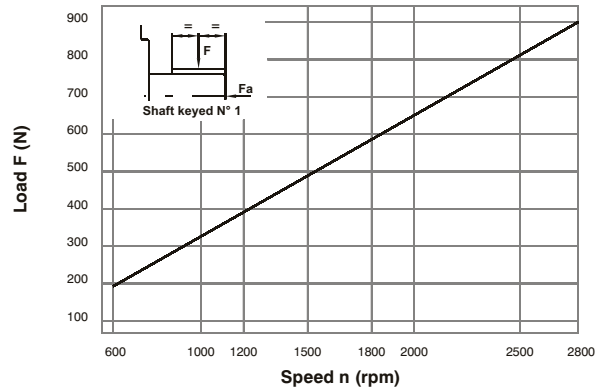

Maximum axial load permissible Fa = 800 N

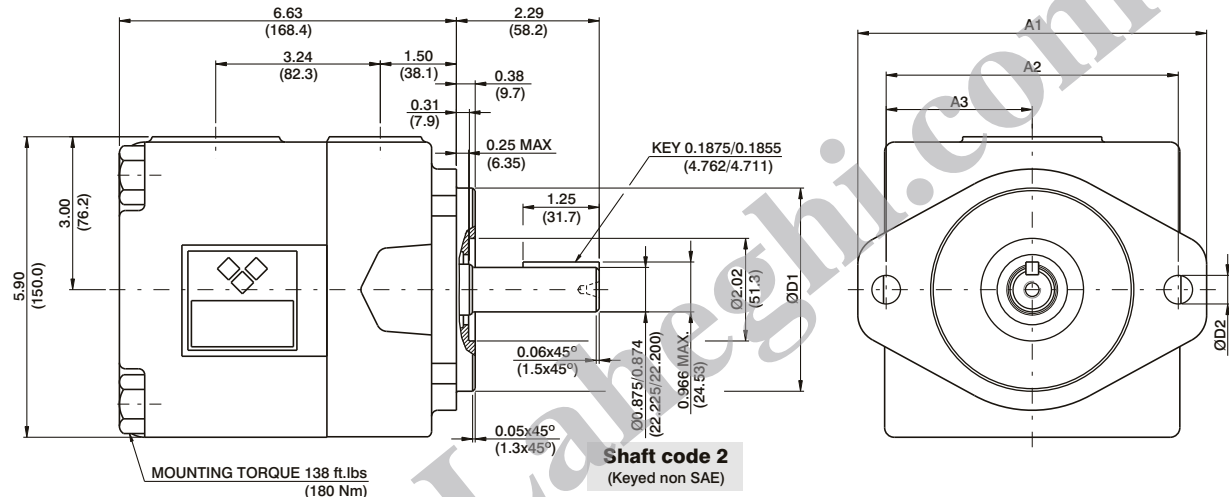
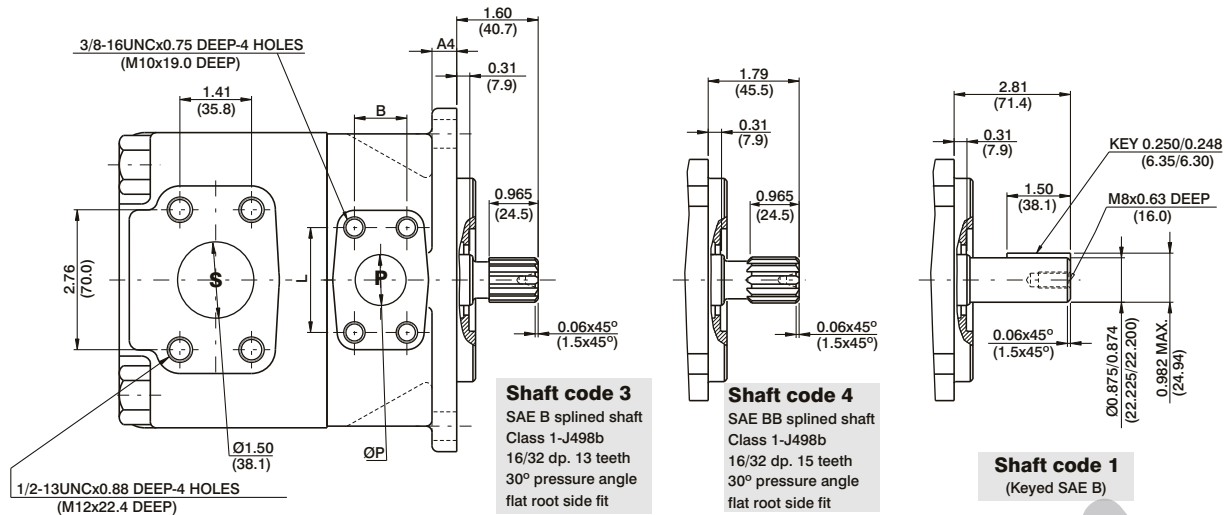

| Mounting | VT7QC1 | | VT7QC2 | |
|----------|----------------------------------|----------------------------------|--------|-------|
| | SAE B | SAE C | SAE B | SAE C |
| ØD1 | 4.000 (101.60) 3.998 (101.55) | 5.000 (127.00) 4.997 (126.94) | | |
| ØD2 | 0.56 (14.3) | 0.69 (17.5) | | |
| A1 | 6.87 (174.5) | 8.36 (212.5) | | |
| A2 | 5.75 (146.0) | 7.13 (181.0) | | |
| A3 | 2.87 (73.0) | 3.56 (90.5) | | |
| A4 | 0.5 (12.7) | 0.62 (15.7) | | |

| ØP | L | B |
|--------------|--------------|--------------|
| 0.75 (19.05) | 1.874 (47.6) | 0.874 (22.2) |
| 1.00 (25.4) | 2.06 (52.4) | 1.03 (26.2) |

| Shaft torque limits in ³ /rev x psi (ml/rev x bar) | |
|---|---------------|
| Shaft | Vp x p max. |
| 1 | 14473 (16500) |
| 2 | 12666 (14300) |
| 3 | 18246 (20600) |
| 4 | 19309 (21820) |

OPERATING CHARACTERISTICS - TYPICAL (24 cST)

| Series | Volumetric Displacement Vp | Flow q (lpm) & n = 1500 rpm | | | | Input power p (kW) & n = 1500 rpm | | | |
|---------------------|----------------------------|-----------------------------|-------------|-------------|-------------|-----------------------------------|-------------|-------------|-------------|
| | | p = 0 bar | p = 140 bar | p = 240 bar | p = 300 bar | p = 7 bar | p = 140 bar | p = 240 bar | p = 300 bar |
| 003 | 10.8 ml/rev | 16.2 | 11.9 | 8.1 | -- | 1.3 | 5.3 | 7.8 | -- |
| 005 | 17.2 ml/rev | 25.8 | 21.5 | 17.7 | 13.7 | 1.4 | 7.5 | 12.2 | 14.9 |
| 006 | 21.3 ml/rev | 31.9 | 26.5 | 22.0 | 18.0 | 1.5 | 8.9 | 14.7 | 18.0 |
| 008 | 26.4 ml/rev | 39.6 | 34.1 | 29.6 | 25.6 | 1.6 | 10.7 | 17.7 | 21.8 |
| 010 | 34.1 ml/rev | 51.1 | 45.7 | 41.2 | 37.2 | 1.7 | 13.4 | 22.3 | 27.5 |
| 012 | 37.1 ml/rev | 55.6 | 50.2 | 45.7 | 41.7 | 1.7 | 14.4 | 24.1 | 29.8 |
| 014 | 46.0 ml/rev | 69.0 | 63.5 | 59.0 | 55.0 | 1.9 | 17.6 | 29.5 | 36.5 |
| 015 | 50.5 ml/rev | 75.1 | 69.6 | 65.1 | 61.1 | 2.0 | 18.0 | 32.0 | 39.5 |
| 017 | 58.3 ml/rev | 87.4 | 82.0 | 77.5 | 73.5 | 2.1 | 19.0 | 36.9 | 45.7 |
| 020 | 63.8 ml/rev | 95.7 | 90.2 | 85.7 | 81.7 | 2.2 | 23.8 | 40.2 | 49.8 |
| 022 ²⁾ | 70.3 ml/rev | 105.4 | 100.0 | 95.5 | 91.5 | 2.3 | 26.1 | 44.1 | 50.3 |
| 025 ^{1,3)} | 79.3 ml/rev | 118.9 | 113.5 | 109.0 | -- | 2.5 | 29.2 | 49.5 | -- |
| 028 ^{1,4)} | 88.8 ml/rev | 133.2 | 127.7 | 124.5 | -- | 2.8 | 32.7 | 48.5 | -- |
| 031 ^{1,4)} | 100.0 ml/rev | 150.0 | 144.5 | 141.3 | -- | 2.8 | 36.5 | 54.4 | -- |

1) 025-028-031 = 2500 R.P.M. max. 2) 022 = 275 bar max. int. 3) 025 = 240 bar max. int. 4) 028-031 = 210 bar max. int.
 -- Not to use because internal leakage greater than 50% of theoretical flow.